



Curated Underfoot Collection

Mannington
COMMERCIAL



Cover: Forte (Modular) – Monochrome 95304

Carpet Installation – Vertical Ashlar

Above: Tesso (Modular) – Monochrome 95304, Gemma Moonslice (LVT) NAT 301



Atto (LVT) Sepia CU301



Glint (Modular) – Worn Leather 85302
Carpet Installation – Vertical Ashlar



Modo (Modular) – Sandstone 53303
Carpet Installation – Vertical Ashlar



Miro (Modular) – Sepia 83301
Atto (LVT) – Sepia CU301
Carpet Installation – Vertical Ashlar

Xpress Fusion

Rubber Transition Strip

When carpet and LVT adjoin, there are often differences in product heights. Eliminate the problem with Fusion Rubber Transition Strips. Place Fusion Strips wherever carpet tile meets LVT to create a subtle transition with minimal visual interruption. Fusion Strips are budget friendly and easy to install, resulting in a more attractive, high-performance floor.

Product Information

- > 2.125" reduction width, 6' length
- > 20 pieces of 6' sections per carton (120 lin ft)

5 Xpress Colors

Platinum Metallic 117



Gray Beige 209



Charcoal 217



BlackBrown 523



Black 701



Compact Mixed Flooring Reducer

Fusion Rubber Transition Strips provide a 6-7 mm reduction over 2.125 inches that are easy to install.

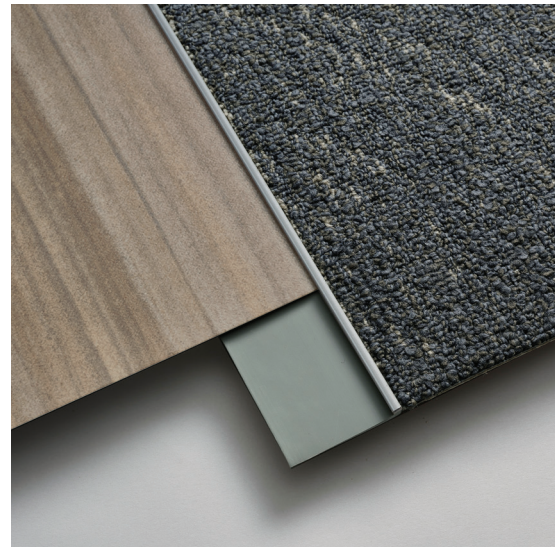
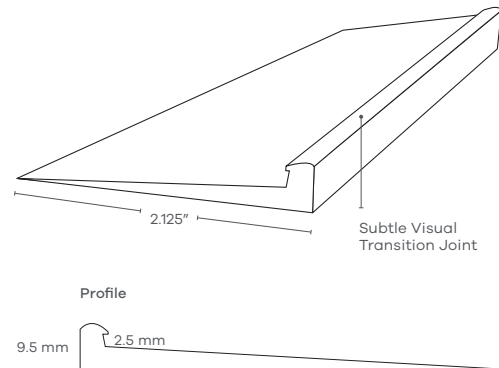

Environmental Attributes

- > FloorScore Certified; CDPH v 1.2 - 2017
- > May contribute to LEED credits

Curated Underfoot LVT | 2.5 mm Product Availability

Product Name	Product Code	Surface Finish - Ceramic	18" x 18"	Variability
2.5 MM				
Atto Stucco	CUR-CU300	•	•	low
Atto Monochrome	CUR-CU304	•	•	low
Atto Sepia	CUR-CU301	•	•	low
Atto Worn Leather	CUR-CU302	•	•	low
Atto Sandstone	CUR-CU303	•	•	low



Proudly made in the USA
BABAA Compliant

Color/Pattern Variability

Color and visual variation are inherent in all resilient products. Variability can fluctuate from slight or significant, and from tile to tile. Our pattern variability ratings range from low (little variation) to high (significant variation).

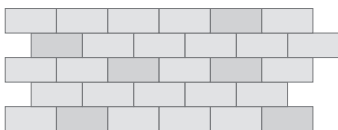

Low
Slight variation

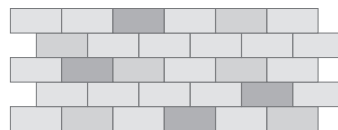

Medium
Moderate variation



High
Substantial variation



Success Is in Our Science

Quantum Guard Elite is a proven, patented technology that provides the ultimate solution for all aspects of LVT performance.

- > Highest scratch resistance in the industry
- > Engineered for best-in-class dimensional stability
- > Superior impact resistance
- > Cuts cleanly for highest quality installation
- > Easy no-polish maintenance significantly reduces overall life cycle cost and total cost of ownership
- > Advanced stain resistance

Outperforms in Scratch Resistance

Quantum Guard Elite

Leading Competitor

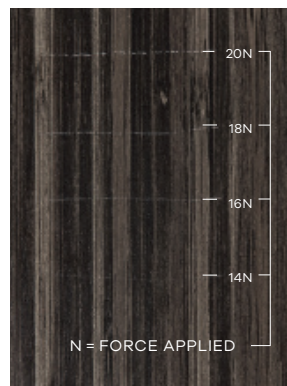
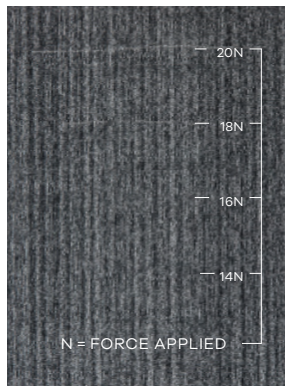

With a patented two-part wear layer and aluminum oxide infused top coat, Quantum Guard Elite offers superior scratch resistance vs. the leading competitor.

Complete Multi-Layered Protection
Quantum Guard Elite combines a hard wear layer and a flexible wear layer for superior durability with the added protection of our proprietary aluminum oxide technology.

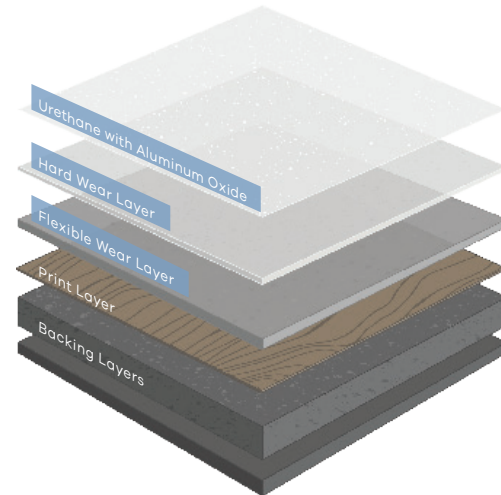

Best-in-Class Dimensional Stability

Quantum Guard Elite

Leading Competitor

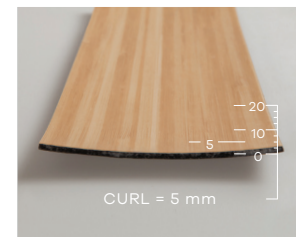
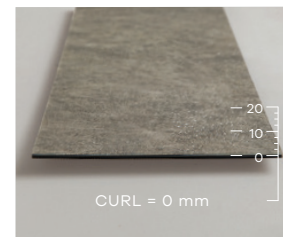

LVT with Quantum Guard Elite is fully engineered to offer the perfect balance of hardness and flexibility, which helps prevent product failures in commercial environments. (Products exposed to 80° C for six hours.)

Warranted to Work

Products with Quantum Guard Elite feature our Limited Quantum Guard Elite Wear Warranty and Limited Commercial Warranty.

Defeat Damp Spaces

Your job just got easier. With our comprehensive moisture solutions for LVT, you can defeat the most extreme high moisture conditions.

Best Solutions for:

Any Slab Condition

NO Moisture Testing Required – NO RH limit, NO Testing*

Adhesive

MoistureLoc

*** Conditions**

No hydrostatic pressure | No standing water or visible water stains | Slab is at least 45 days old

Best Solutions for:

Slabs with Intact Vapor Barrier (Class B or better)

Quick pH Testing Required**

Adhesive

pH

V-88

12

MoistureLoc

None

QuickStix® with Moisture Resistant Primer**

12

**** Conditions**

Intact Class B or better vapor barrier | No hydrostatic pressure | No standing water or visible water stains | Slab is at least 45 days old

Best Solutions for:

Unknown Slab Conditions

Moisture Testing Required

Adhesive

RH%

MVER

pH

V-88

95

10

12

MoistureLoc

None

None

None

XpressStep LVT & Sheet

98

10

12

QuickStix® with Premium Universal Primer (with IVB)

99

18

12

QuickStix® with Premium Universal Primer (No IVB)

95

10

12

V-95

85

5

9

No Moisture Testing Required*

Solutions crafted for high-moisture conditions. Defeat moisture issues with carpet backings that do not require moisture testing*.

We have solutions for broadloom and modular carpet to make moisture worries evaporate. From backing options to adhesives to a dry installation system, explore solutions that defeat moisture concerns while enhancing the performance of your floor.



	Infinity 2 Pressure Sensitive Adhesive	XpressStep™ Spray Adhesive	FreLock Tabs	Integra-2 Adhesive	Ultra Adhesive
Infinity® 2 Modular Backing	✓	✓	✓		
Infinity® 2 MG Modular Backing	✓	✓	✓		
Infinity® 2 MG Cushion Modular Backing	✓	✓			
rEvolve® II PVC-Free Modular Backing	✓	✓			
Integra® HP Broadloom Backing				✓	
UltraBac® RE Broadloom Backing					✓

* Assumes intact vapor barrier, no standing water or stained concrete, no hydrostatic pressure, and for our broadloom backings (Integra® HP and UltraBac® RE) pH levels must never exceed 10. Please refer to our installation instructions for further details.

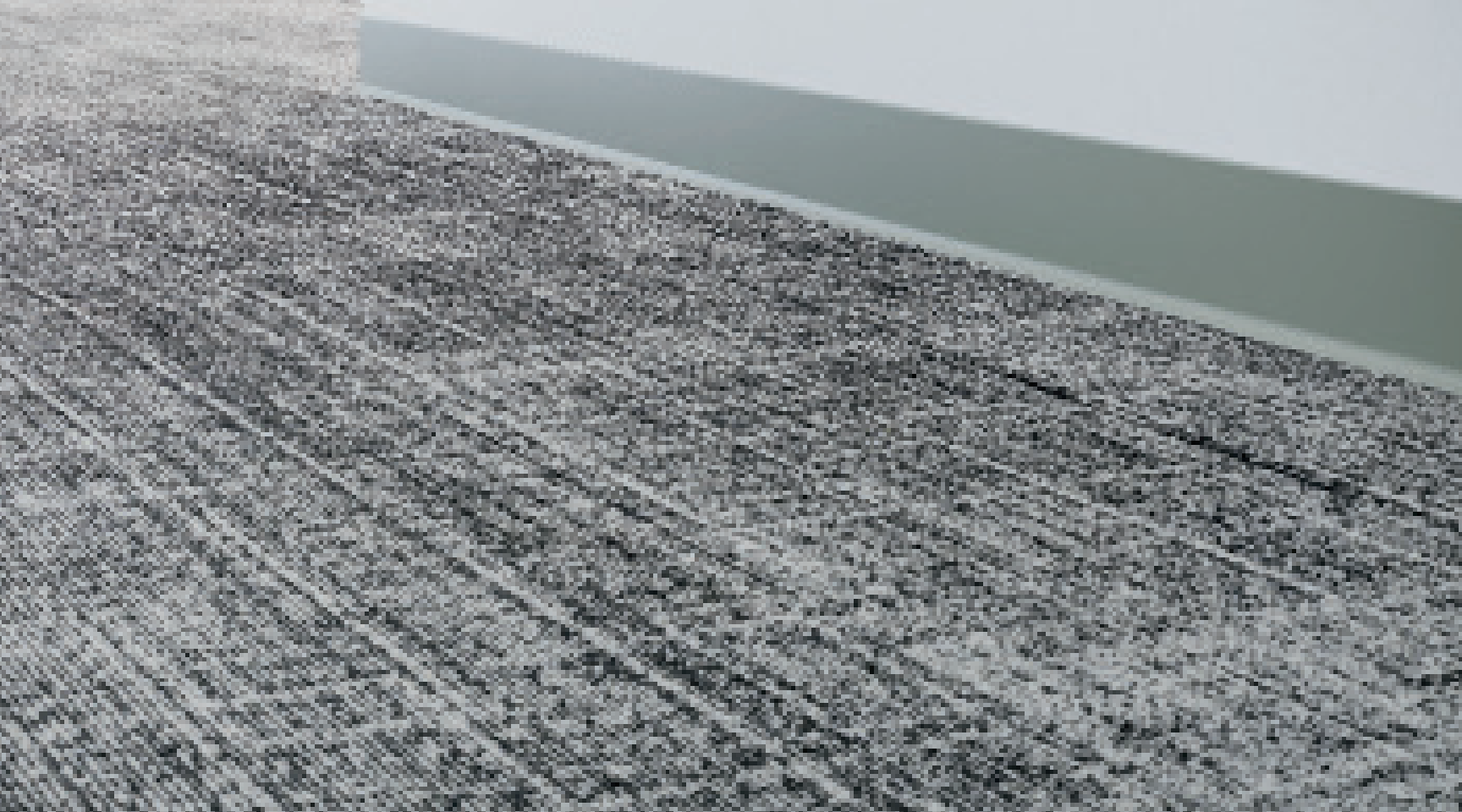

Available Profile Heights	BurkeBase® Premium TS Molded 1/8"	BurkeBase® Type TP 1/8"	BurkeBase® Type TV 1/8"	BurkeBase® Type TV .080"
4" (102 mm)		2.5" (64 mm)	2.5" (64 mm)	2.5" (64 mm)
6" (152 mm)		4" (102 mm)	4" (102 mm)	4" (102 mm)
		4.5" (114 mm)	4.5" (114 mm)	6" (152 mm)
		6" (152 mm)	6" (152 mm)	
	Coved	Coved or Toeless	Coved or Toeless	Coved or Toeless

Warranty This product is backed by our Limited 5-Year Commercial Warranty.

Corners BurkeBase® Premium Type TS factory molded corners are available with 4" and 6" coved corners. Must be ordered at time of wall base order to ensure color match (Outside Corners Only).
 BurkeBase® Type TP/TV pre-formed corners are available in all profile heights. Must be ordered at time of wall base order to ensure color Minimums apply.

Custom Colors Please make final selection for all colors from actual product samples.
 For samples and information, visit manningtoncommercial.com or call 800.241.2262.

The molecular strength of type 6,6 nylon delivers greater resilience against matting and resists abrasive wear, keeping carpet looking better longer.

Easier to Maintain

- ✔ XGUARD® Stain Resistant Technology provides long-term stain resistance.
- ✔ ColorSafe® Bleach Resistant Technology resists color fade-out from bleach spills.
- ✔ Moisture-barrier backings are built to withstand aggressive wet cleanings.

Sustainable Solutions

- ✔ Supported with third party verified EPDs and HPDs.
- ✔ Infinity® 2 Modular and rEvo™ II backings are NSF/ANSI 140 Gold Certified and contain recycled content.
- ✔ Recognizing the impact that the built environment can have on Earth's climate and health, Mannington Commercial is improving operations and offsetting cradle-to-gate embodied carbon by 105% on this collection, as part of our commitment to helping customers take positive action through their projects.

Backing Advantages

- ✔ Infinity® 2 and rEvo™ II Modular backings provide exceptional performance with a moisture barrier as well as superior tuft bind and dimensional stability with a limited lifetime warranty.
- ✔ rEvo™ II is a PVC-free modular backing. For additional backing options please visit our website.
- ✔ UltraBac® RE broadloom backing offers strong performance and excellent environmental benefits with a limited lifetime warranty.
- ✔ Integra® HP is a high-performance broadloom backing with an impermeable moisture barrier, featuring a limited lifetime wick-back warranty.

TARR

- ✔ Curated Underfoot Collection carpet was specifically designed with a 3.5 TARR rating for heavy use environments with substantial foot traffic. This includes conference rooms, open office areas and classrooms. Our TARR rating is tested and verified by an independent lab.

Proven by Third-Party Testing | Every carpet we make at Mannington Commercial is third-party tested and proven to exceed industry standards in appearance retention, texture retention, fire safety factors and static generation, and our modular carpet exceeds industry standards in dimensional stability—so you can be sure that the carpet you specify will perform for years to come.



Style	2.5 mm
Construction	Luxury Vinyl Tile Non-ortho Phthalate
Classification	ASTM F1700 Class III, Type B
Overall Thickness	0.098" (2.5 mm)
Wear Layer Thickness	20 mil (0.51 mm)
Wear Layer	Quantum Guard Elite®
Edge Treatment	Unbeveled
Sizes	18" x 18"(457 x 457 mm)
Colors	5
Environmental Data	
Indoor Air Quality	FloorScore Certified; CDPH v12-2017
Product Declarations	Third party verified EPD, HPD
Carbon Offset	105% Cradle to Gate (A1-A3), see website for additional information
LEED	May contribute to LEED credits: Building Product Disclosure & Optimization - EPDs Building Product Disclosure & Optimization - Sourcing Raw Materials Building Product Disclosure & Optimization - Material Ingredients; IEQc2 - Low Emitting Materials
Manufacturing	Madison, GA (USA) - ISO 14001 EMS & ISO 9001 QMS Registered, +Vantage Vinyl Verified Silver
Warranty	
	Limited 15-Year Commercial Warranty Limited 15-Year Quantum Guard Elite® Wear Warranty

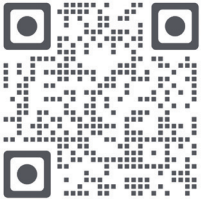

View full collection specs.

Style	Sizes	Face Weight	Colors	Face Fiber
Forte	12" x 36"	23 oz/yd ² (780 g/m ²)	5	Type 6,6 Nylon
Glint	12" x 36"	17 oz/yd ² (482 g/m ²)	5	Type 6,6 Nylon
Miro	12" x 36"	17 oz/yd ² (482 g/m ²)	5	Type 6,6 Nylon
Modo	12" x 36"	18 oz/yd ² (482 g/m ²)	5	Type 6,6 Nylon
Tesso	12" x 36"	18 oz/yd ² (482 g/m ²)	5	Type 6,6 Nylon

Testing

Dimensional Stability (Aachen Test)	Passes
Electrostatic Propensity (AATCC 134)	Less than 3.0 kV
Radiant Panel (ASTM E648)	≥ 0.45 watts/cm ² , Passes (Class 1)
Smoke Density (ASTM E662)	≤ 450-Passes
Methenamine Pill Test (ASTM D2859)	Passes
Hexapod (ASTM D5252) TARR Rating	3.5

Environmental Data

NSF/ANSI 140 Certification	Infinity 2 Modular - Gold / rEvolve II Modular - Gold
Recycled Content	Contains Recycled Content
Indoor Air Quality	CRI Green Label Plus Certified
Product Declarations	Third Party Verified EPD, HPD
Carbon Offset	105% Cradle to Gate (A1 - A3), visit website for more information
LEED Scoreboard	May Contribute to LEED credits: Building Product Disclosure & Optimization - EPDs Building Product Disclosure & Optimization - Sourcing Raw Materials Building Product Disclosure & Optimization - Material Ingredients; IEQc2 - Low Emitting Materials
Manufacturing	Calhoun, Georgia (USA) - ISO 14001 Certified, +Vantage Vinyl Verified Silver

Warranty

Limited Lifetime Wear & Backing
 Limited 15-Year XGUARD® Stain Resistant
 Limited 15-Year ColorSafe® Bleach Resistant

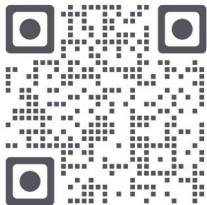

[View full collection specs.](#)

- Specifications are based on averages from normal manufacturing tolerances. Such variations do not affect product performance.
- Protective chair pads are recommended under office chairs with roller casters to preserve appearance and avoid premature wear.
- As with all quality carpets, slight variation in color may occur from dye lot to dye lot.
- Backing or other materials may be changed without prior notice when shortages occur or when technological advancements provide improved product performance.
- This product is intended solely for use as an indoor floor covering and is not recommended or sold for any other purpose.
- The inherent characteristics of geometric linear patterns can result in double-dark or double-light lines at the seam and to some extent pattern run-off or bias. This is not a manufacturing defect, and as such, should be considered when selecting a modular carpet installation method.
- Please make your final selection from an actual swatch. To order samples, go to manningtoncommercial.com or call 800.241.2262